

AFM8 Inner Pin Crimp Tool
Part Number: 390-002

**HOW TO USE DANIELS AFM8 (M22520/2-01)
 BASIC HAND CRIMP TOOL AND RELATED POSITIONERS**

GENERAL INFORMATION

1. Designation AFM8 (M22520/2-01) refers to basic hand tool without positioners. Wire crimp range 20 AWG to 32 AWG.
2. The tool has a double action ratchet. Note that the tool cannot be opened without completing the cycle.

TOOL PREPARATION

1. Tool must be in open position.
2. Remove safety clip from positioner guide.
3. Select Positioner for contact to be crimped.
4. Insert Positioner into positioner guide and turn 90 degrees until bayonet pins lock.
5. Install safety clip into positioner guide (optional).
6. Wire size and corresponding selector number are shown on data plate.
7. With tool still in open position, raise and rotate selector knob until number indicated on data plate for wire size to be crimped is in line with Sel. No. arrow.

CRIMPING INSTRUCTIONS

1. Insert contact and prepared wire into indenter opening from side opposite the Positioner.
2. Squeeze handles together until ratchet releases. Handle will return to the open position. Remove crimped contact and wire.

REMOVING POSITIONER

1. Remove safety clip and reverse procedure described in step four (4) above.

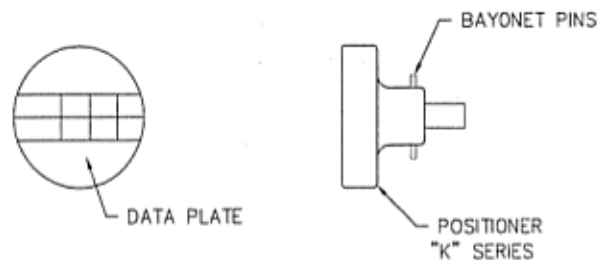
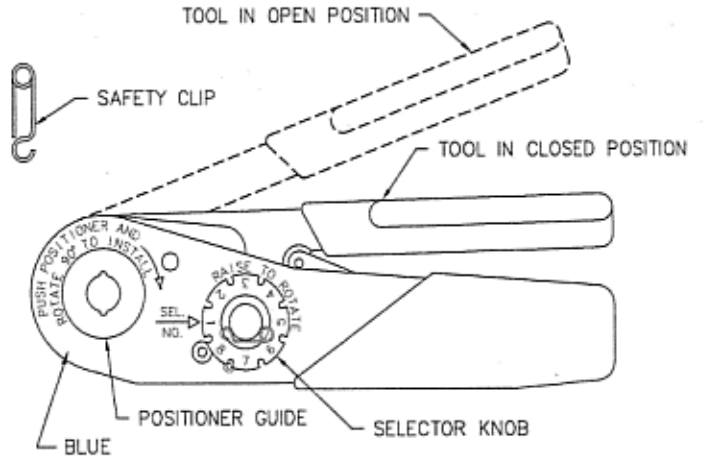

GAGE PART NO.	A GO DIA	B NO-GO DIA	SEL NO
G125	.0390	.0440	8

CAUTION!
DO NOT CRIMP GAGE!

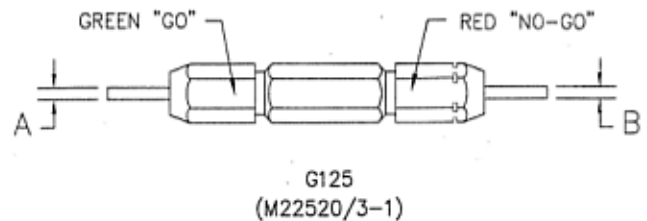

GAGING LIMITS

SELECTOR NUMBER	A ±.0001 GO DIA	B ±.0001 NO-GO DIA
1	.0130	.0180
2	.0160	.0210
3	.0190	.0240
4	.0220	.0270
5	.0260	.0310
6	.0300	.0350
7	.0340	.0390
8	.0390	.0440

GAGING INSTRUCTIONS

"GO" GAGING

Operate tool to fully closed position. Maintain firm hand pressure on the tool handles. Insert "GO" gage end as shown. Gage must pass freely between indenter tips.

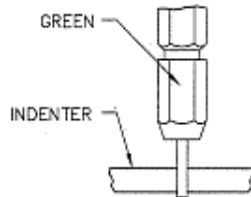

"NO-GO" GAGING

Operate tool to fully closed position. Maintain firm hand pressure on the tool handles. Insert "NO-GO" gage end as shown. The "NO-GO" gage may partially enter the indenter opening, but must not pass completely through the opening.

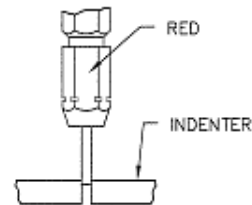

CARE OF TOOL

It is a good practice to keep indenter tips free of residual color band deposits and other debris. A small wire brush may be used for this purpose.

We strongly recommend that you:

1. DO NOT immerse tools in cleaning solution.
2. DO NOT spray oil into tool to lubricate.
3. DO NOT attempt to disassemble tool or make repairs.

This is a precision crimp tool and should be handled as such.