

REV	MCO	DWN	DATE
A	20207546	DGS	09-JAN-07
B	20235519	JBC	08-MAR-08

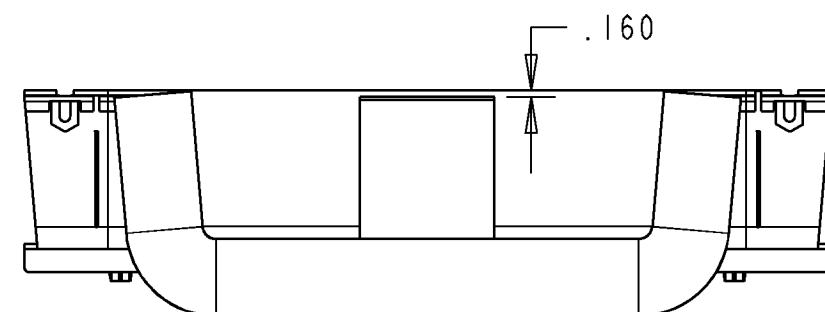
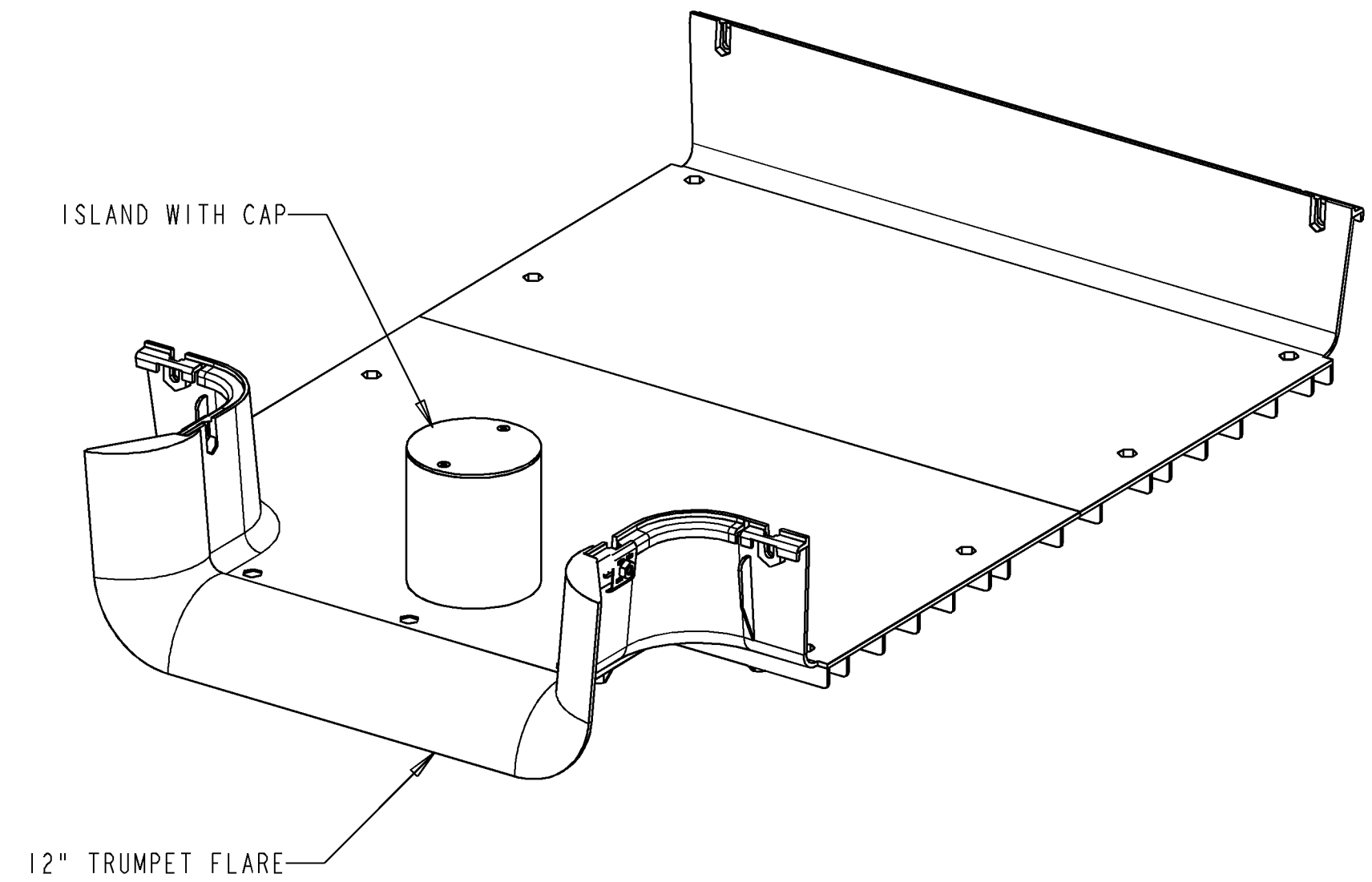
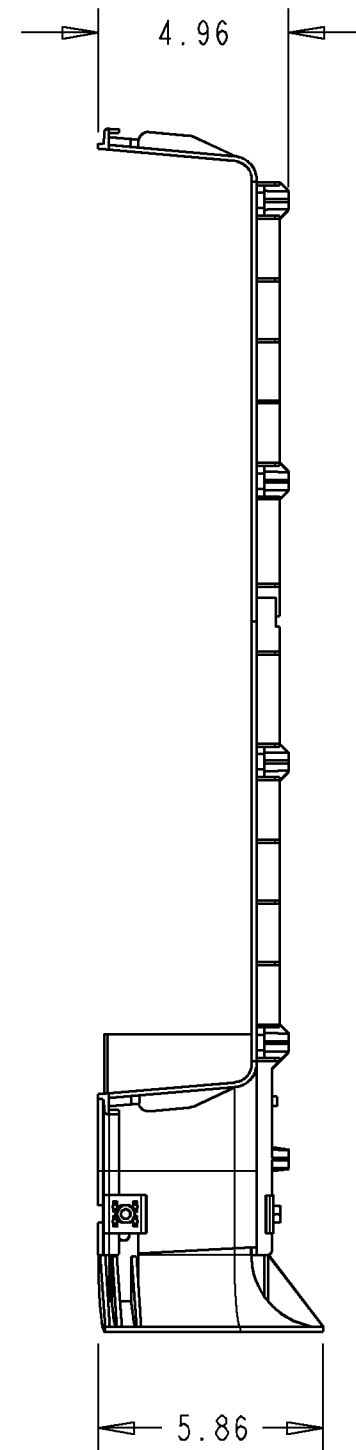
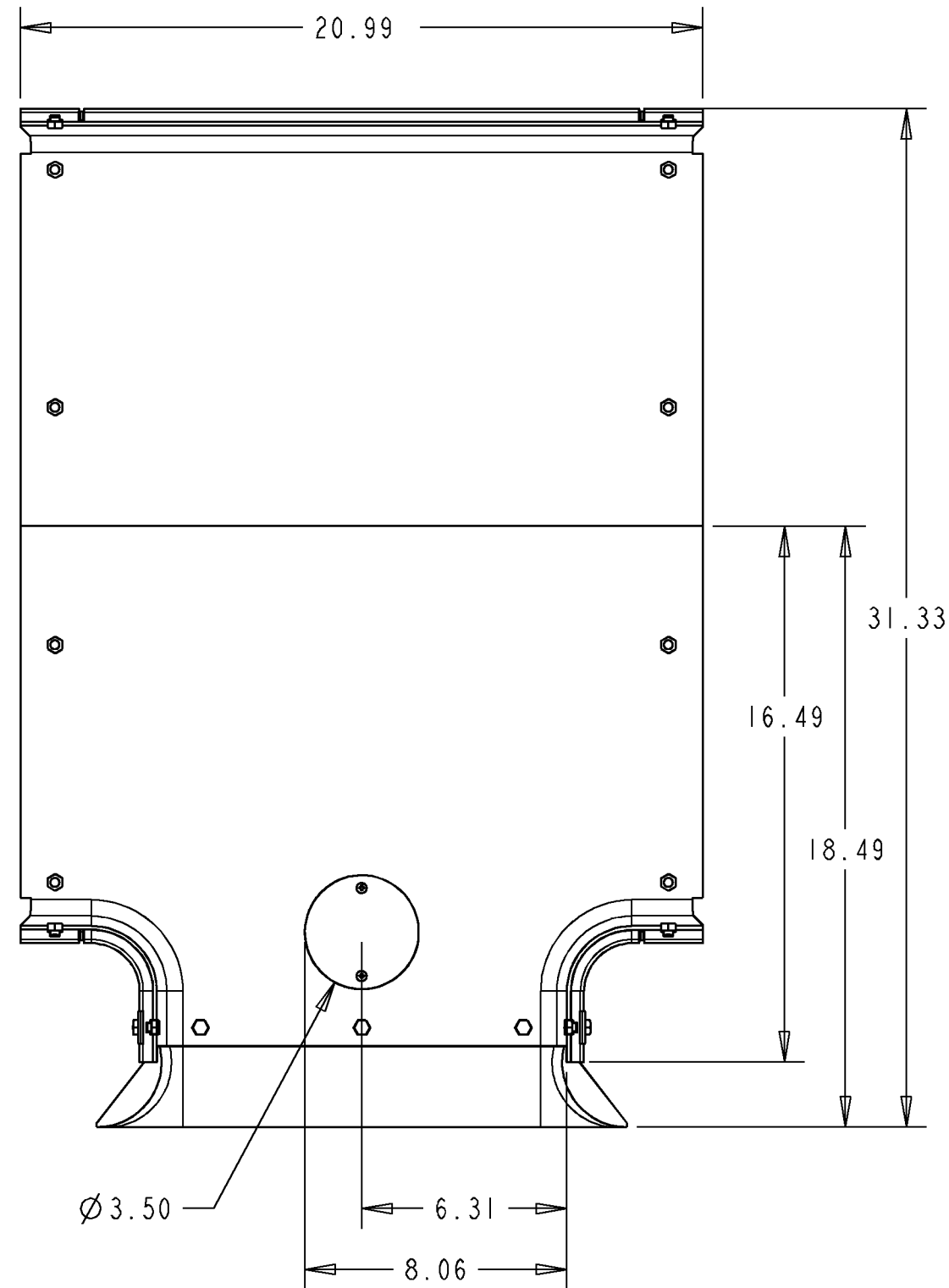

NOTES:

1. KIT INCLUDES THE FOLLOWING:

(1) 24" TO 12" EXIT FGS TEE/ISLAND KIT ASSEMBLY, COMPRISED OF THE FOLLOWING:

- (1) 24" TEE WITH 12" EXIT
- (1) MOUNTED ISLAND
- (1) ISLAND MOUNT BRACKET AND COVER
- (1) ASSEMBLED TRUMPET FLARE



INFORMATION ON THIS DOCUMENT IS PROPRIETARY TO ADC AND SHALL NOT BE USED, COPIED, REPRODUCED OR DISCLOSED IN WHOLE OR IN PART WITHOUT WRITTEN CONSENT OF ADC.		TITLE ISLAND KIT, 24" FGS TEE INSTALLATION DRAWING	
ALL DIMS AND TOLERANCES ARE INCHES UNLESS OTHERWISE SPECIFIED	.XX:±N/A .XXX:±N/A ANGULAR:±N/A	C SIZE	DRAWING NUMBER 1385924
DO NOT SCALE DRAWING		ENGR: DEREK SAYRES DWN: JOHN PFARR	B REV
			SHT. 1 OF 4

FGSB-ISLAND-H/F	BLACK
FGSO-ISLAND-H/F	ORANGE
FGS-ISLAND-H/F	YELLOW
CATALOG NUMBER	COLOR

DIMENSIONS IN INCHES
THIRD ANGLE PROJECTION

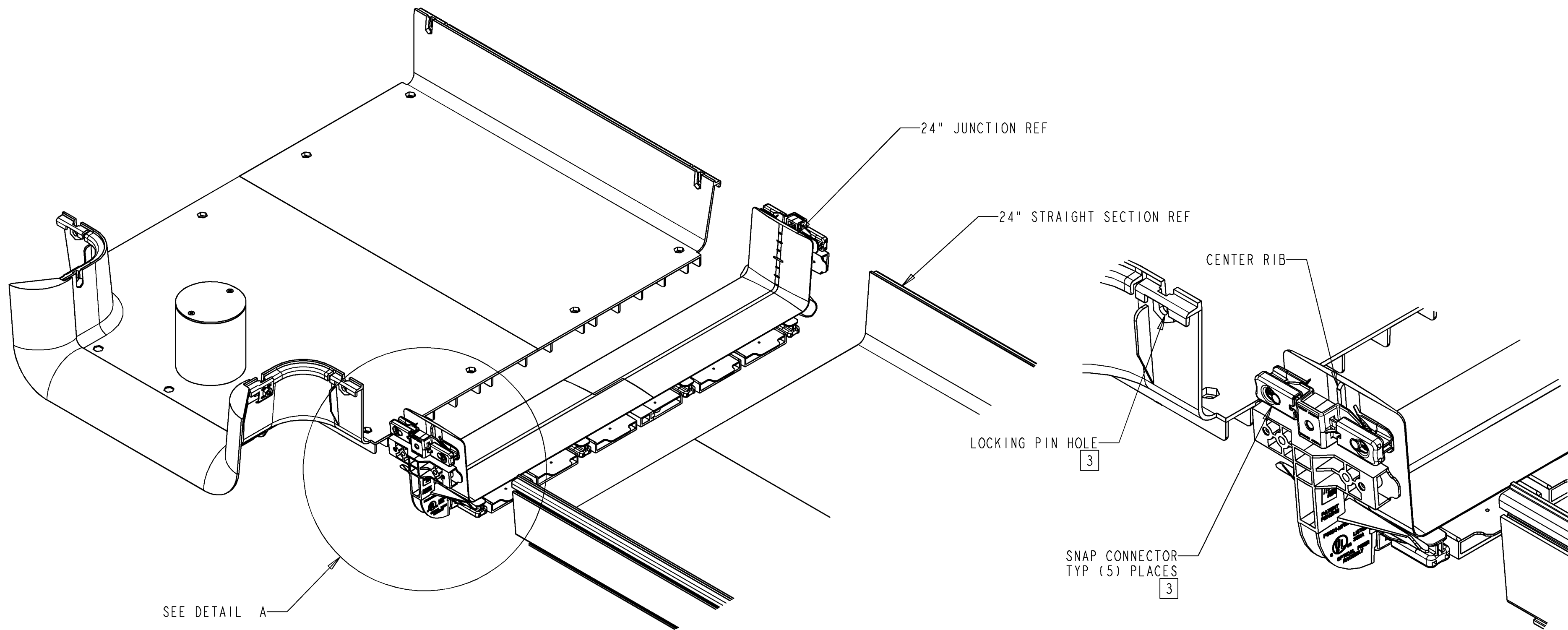

FIGURE 1

SCALE 0.250

DETAIL A

SCALE 0.500

ASSEMBLY INSTRUCTIONS:

2. SLIDE ONE EXIT OF THE TEE KIT INTO JUNCTION UNTIL FIRMLY SEATED AGAINST THE CENTER RIB. (SEE FIGURE 2).
- 3 ENSURE LOCKING PINS ON SNAP CONNECTOR ARE ENGAGED IN HOLES IN TEE. (SEE FIGURE 2). ONLY APPLICABLE WITH ADC PART FGS-ISLAND-F.
5. SLIDE THE 24" FIBERGUIDE STRAIGHT SECTION INTO THE JUNCTION UNTIL FIRMLY SEATED AGAINST THE CENTER RIB.
6. TIGHTEN THE (16) JUNCTION SCREWS SUCH THAT THE WASHER HEAD ON THE SCREW IS APPROXIMATELY 1/16" (1.6MM) FROM THE JUNCTION SUPPORT ARM. (SEE DETAIL A). AFTER ALL SCREWS HAVE BEEN TIGHTENED IN THIS MANNER, TIGHTEN ALL SCREWS UNTIL THE WASHER HEAD BOTTOMS OUT.
7. REPEAT ABOVE NOTES FOR THE OTHER EXIT OF THE TEE.

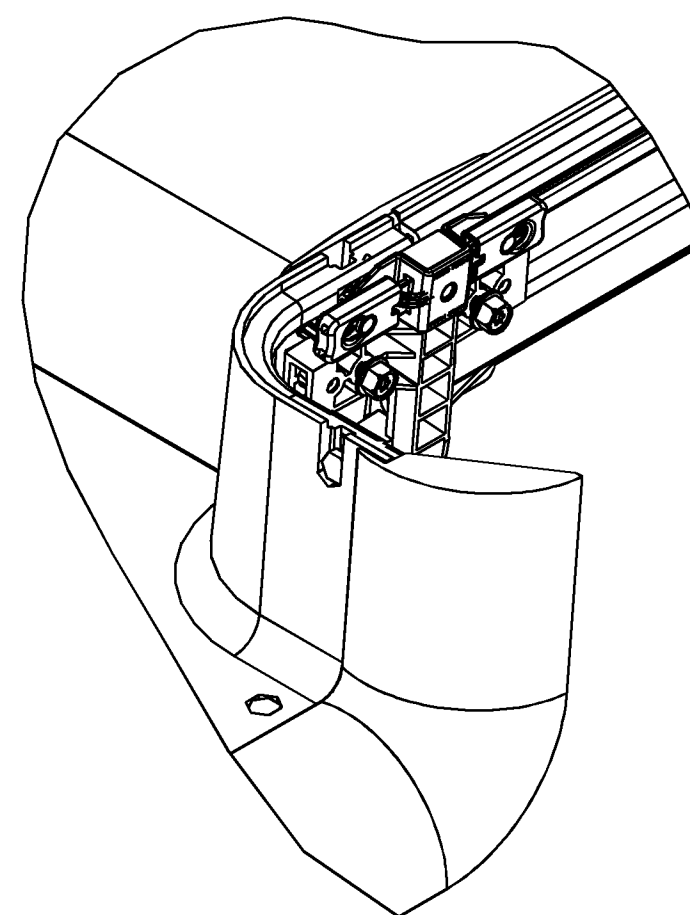

FIGURE 2
COMPLETED ASSEMBLY

SCALE 0.375



INFORMATION ON THIS DOCUMENT IS PROPRIETARY TO ADC AND SHALL NOT BE USED, COPIED, REPRODUCED OR DISCLOSED IN WHOLE OR IN PART WITHOUT WRITTEN CONSENT OF ADC.		TITLE ISLAND KIT, 24" FGS TEE INSTALLATION DRAWING	
ALL DIMS AND TOLERANCES ARE INCHES UNLESS OTHERWISE SPECIFIED	.XX:±N/A .XXX:±N/A ANGULAR:±N/A	C SIZE	DRAWING NUMBER 1385924
DO NOT SCALE DRAWING		ENGR: DEREK SAYRES DWN: JOHN PFARR	B REV
			SHT. 2 OF 4

DIMENSIONS IN INCHES
THIRD ANGLE PROJECTION

A

B

C

D

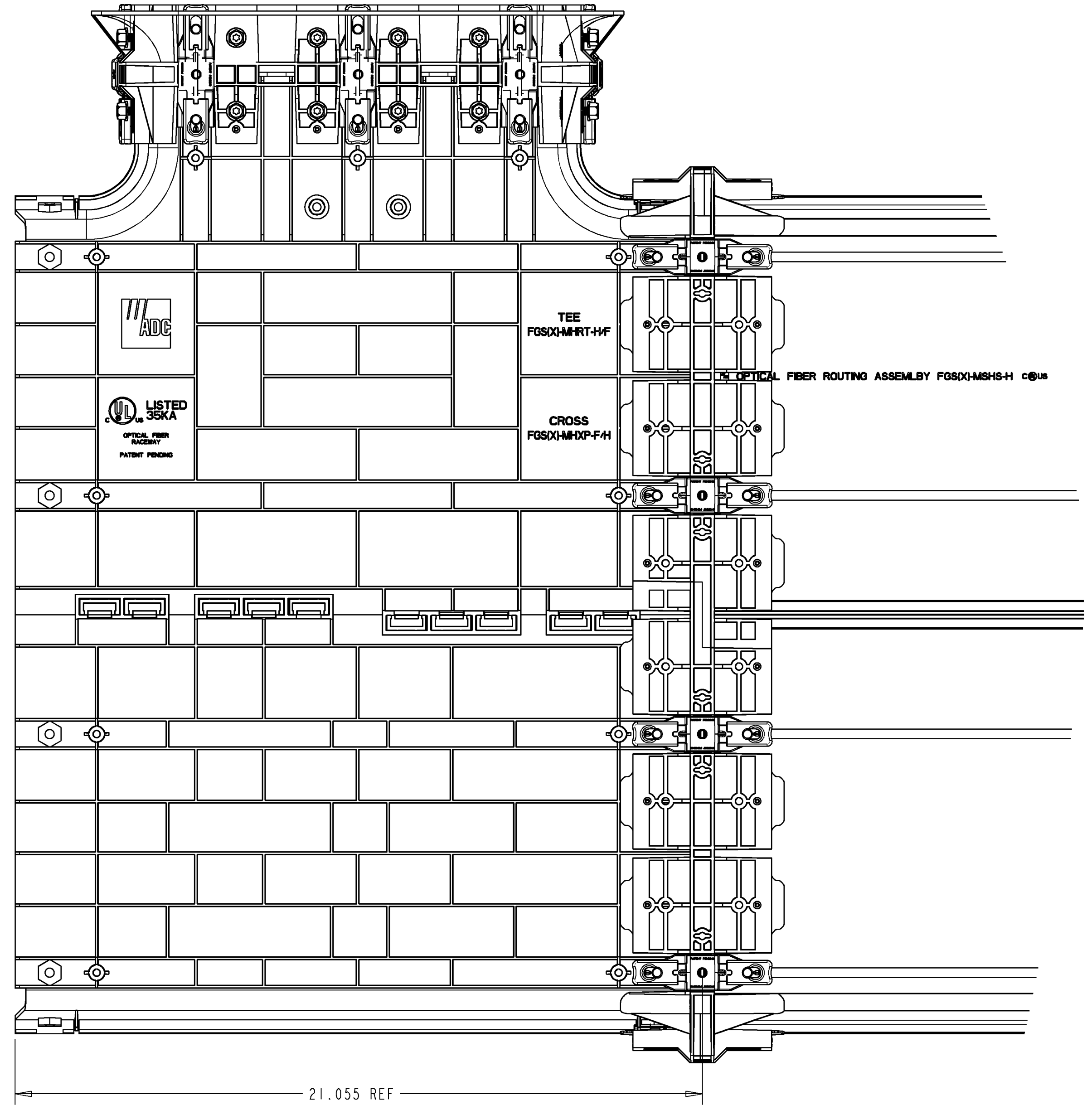

LISTED
35KA
OPTICAL FIBER
RACEWAY
PATENT PENDING

TEE
FGS(X)-M-RT-H/F

CROSS
FGS(X)-M-XP-F/H

OPTICAL FIBER ROUTING ASSEMBLY FGS(X)-M-SH-H c@us

21.055 REF

SCALE 0.375



INFORMATION ON THIS DOCUMENT IS PROPRIETARY TO ADC AND SHALL NOT BE USED, COPIED, REPRODUCED OR DISCLOSED IN WHOLE OR IN PART WITHOUT WRITTEN CONSENT OF ADC.

ALL DIMS AND TOLERANCES ARE INCHES UNLESS OTHERWISE SPECIFIED

TITLE ISLAND KIT, 24" FGS TEE INSTALLATION DRAWING

DRAWING NUMBER 1385924

DO NOT SCALE DRAWING

ENGR: DEREK SAYRES
DWN: JOHN PFARR

SHT. 3 OF 4

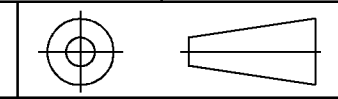

DIMENSIONS IN INCHES
THIRD ANGLE PROJECTION

A

B

C

1

2

3

4

1

2

3

4

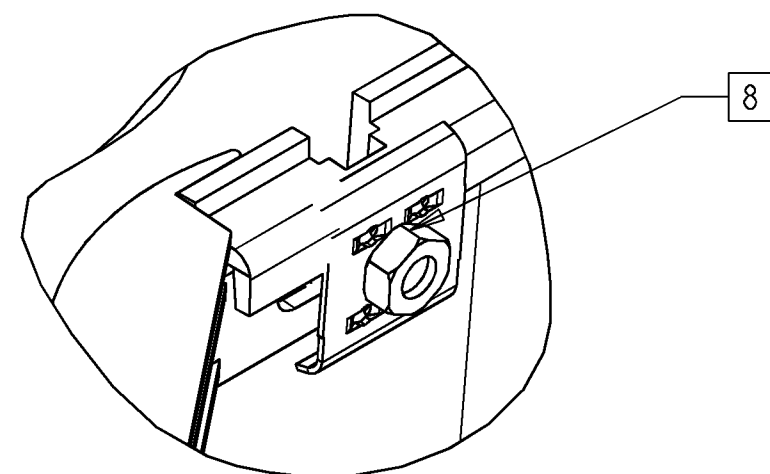
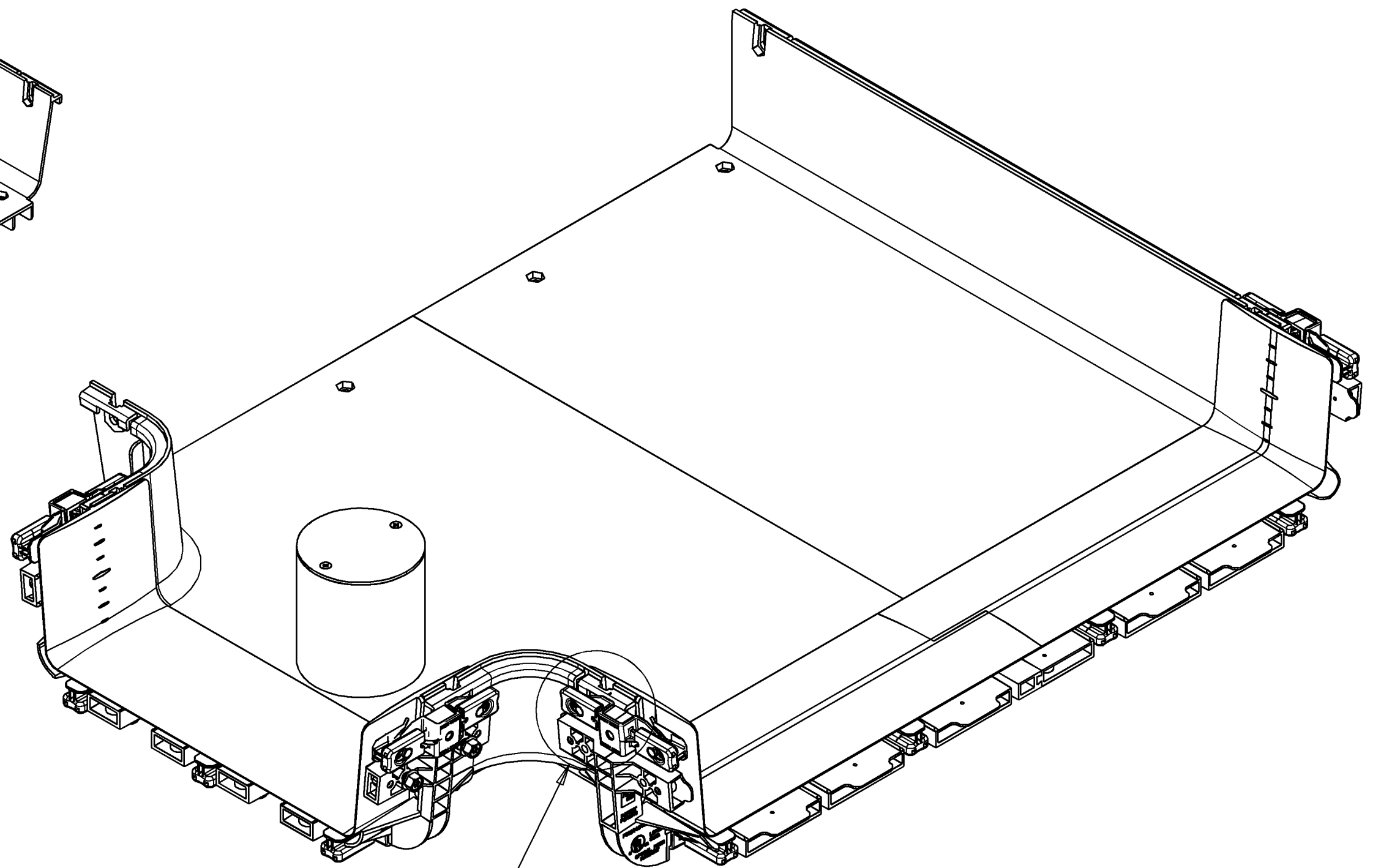
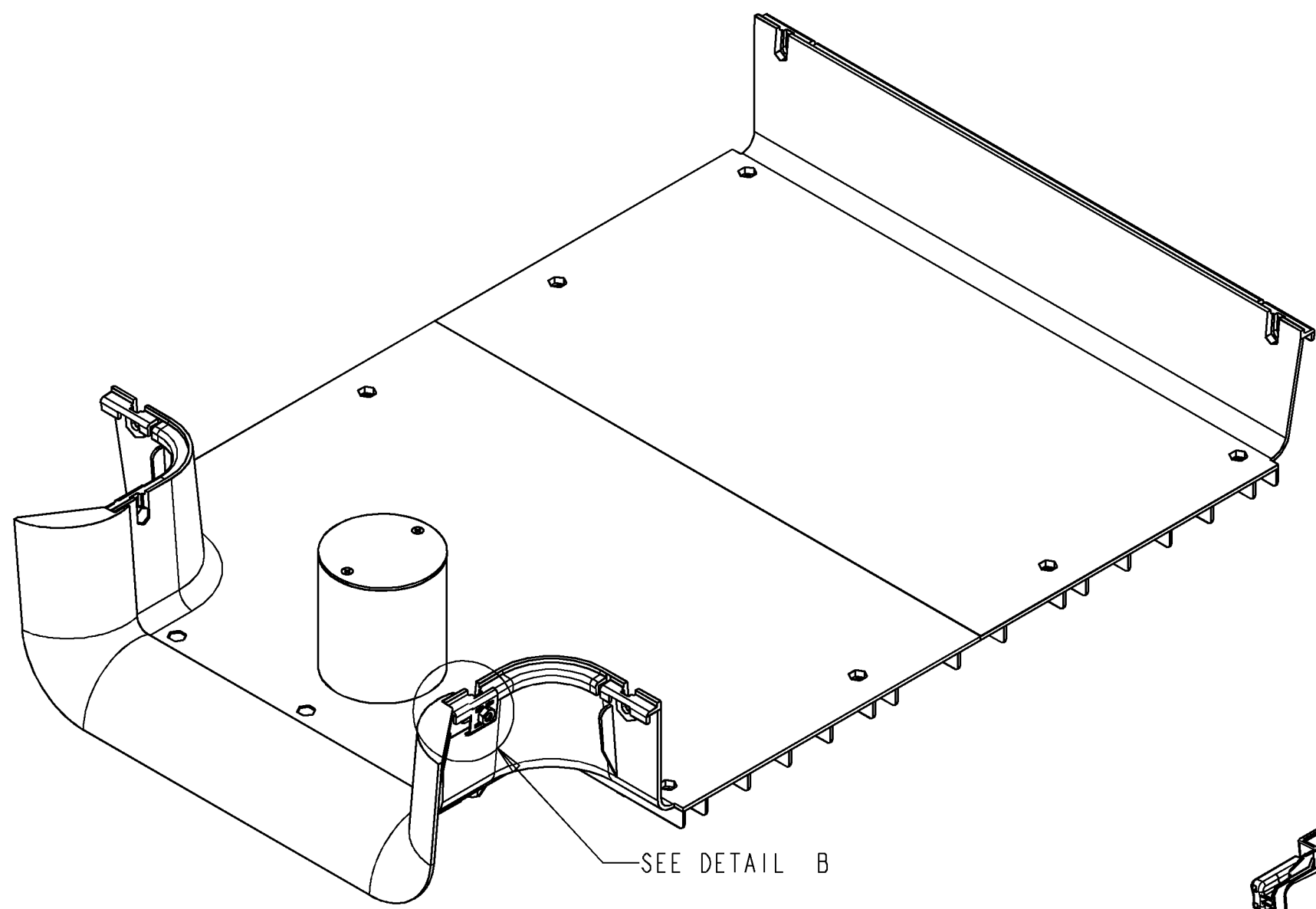

DETAIL B
SCALE 1.000

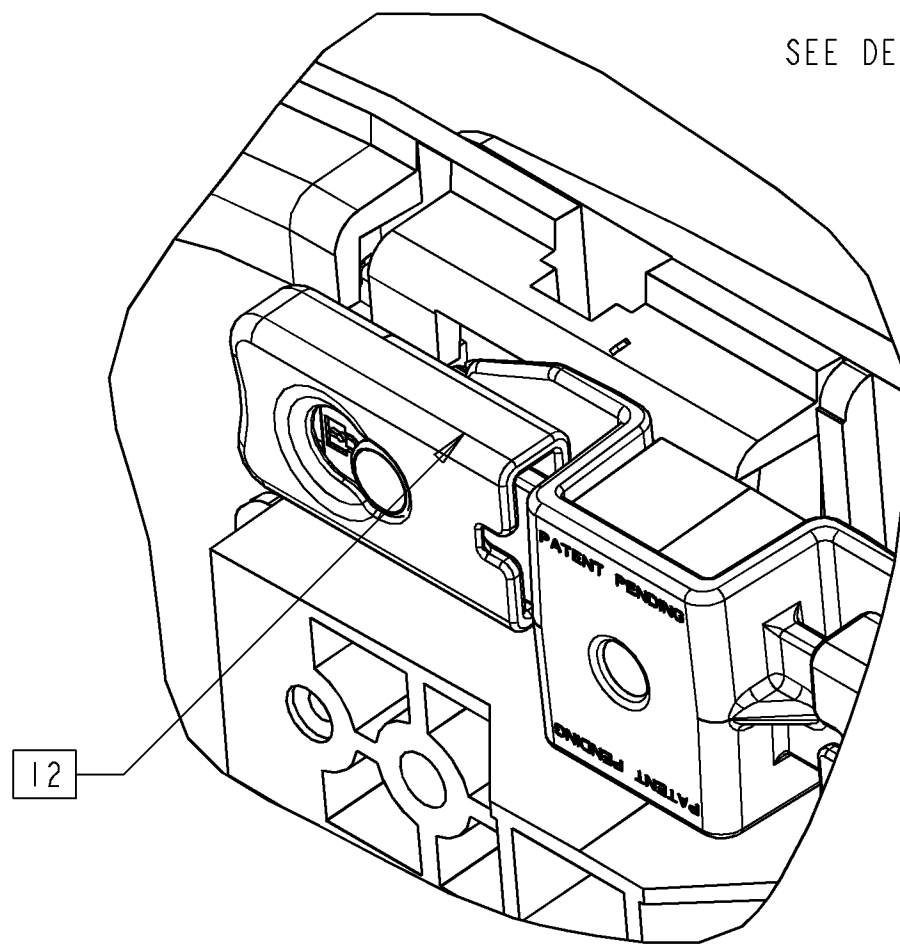

DETAIL C
SCALE 1.500

JUNCTION INSTALLATION (OPTIONAL):

- 8 REMOVE HEX NUTS, RETAINING WASHERS, AND HEX BOLTS SECURING TRUMPET FLARE TO TEE.
- 9. REMOVE TRUMPET FLARE.
- 10. LOOSEN HEX NUTS SECURING ISLAND TO TEE FITTING.
- 11. SLIDE FGS JUNCTION (FGS-JUNC-F) ONTO EXIT OF TEE FITTING AND UNDER ISLAND ASSEMBLY UNTIL FIRMLY SEATED AGAINST THE CENTER RIB.
- 12 ENSURE LOCKING PINS ON SNAP CONNECTOR ARE ENGAGED IN HOLES IN TEE.
- 13. TIGHTEN THE JUNCTION SCREWS PER NOTE 6.
- 14. TIGHTEN HEX NUTS SECURING ISLAND TO TEE FITTING COMPLETELY.

INFORMATION ON THIS DOCUMENT IS PROPRIETARY TO ADC AND SHALL NOT BE USED, COPIED, REPRODUCED OR DISCLOSED IN WHOLE OR IN PART WITHOUT WRITTEN CONSENT OF ADC.		TITLE ISLAND KIT, 24" FGS TEE INSTALLATION DRAWING	
ALL DIMS AND TOLERANCES ARE INCHES UNLESS OTHERWISE SPECIFIED	.XX:±N/A .XXX:±N/A ANGULAR:±N/A	C SIZE	DRAWING NUMBER 1385924
DO NOT SCALE DRAWING		ENGR: DEREK SAYRES DWN: JOHN PFARR	B REV SHT. 4 OF 4

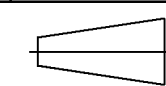
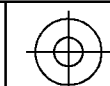

**DIMENSIONS IN INCHES
THIRD ANGLE PROJECTION**